

PARÇA KODU PART CODE	PARÇA ADI PART NAME	ERKEK TERMINAL MALE TERMINAL	a ÖLÇÜSÜ (AYAR) a MEASURE (SET)	s ÖLÇÜSÜ (KALINLIK) s MEASURE (THICKNESS)	Malzeme Material	Kaplama Coating
MS 2113.80 DP	STANDART DIŞI FİŞ K.A.6.3 (0.80) =DP=	0.80	0.55±0.1	0.30±0.05	(CuZn30) Pirinç / Brass	—
MS 2113.80 RP	STANDART DIŞI FİŞ K.A.6.3 (0.80) =RP=	0.80	0.55±0.1	0.30±0.05	(CuZn30) Pirinç / Brass	—
TD 2113.50 RP	STANDART DIŞI FİŞ K.A.6.3 (0.50) =RP=	0.50	0.35±0.1	0.38±0.05	(CuZn30) Pirinç / Brass	—
TD 2113.80 DP	STANDART DIŞI FİŞ K.A.6.3 (0.80) =DP=	0.80	0.55±0.1	0.38±0.05	(CuZn30) Pirinç / Brass	—
TD 2113.80 RP	STANDART DIŞI FİŞ K.A.6.3 (0.80) =RP=	0.80	0.55±0.1	0.38±0.05	(CuZn30) Pirinç / Brass	—
TD 2113.80 RPK	STANDART DIŞI FİŞ K.A.6.3 (0.80) =RPK=	0.80	0.55±0.1	0.38±0.05	(CuZn30) Pirinç / Brass	Kalay / Sn (3-5µ)
TD 2113.80 RÇN	STANDART DIŞI FİŞ K.A.6.3 PASLANMAZ (0.80) =RÇN=	0.80	0.55±0.1	0.40±0.05	Nikel kaplı çelik / Nickel plated Steel	Nikel / Ni (≥1.5µ)

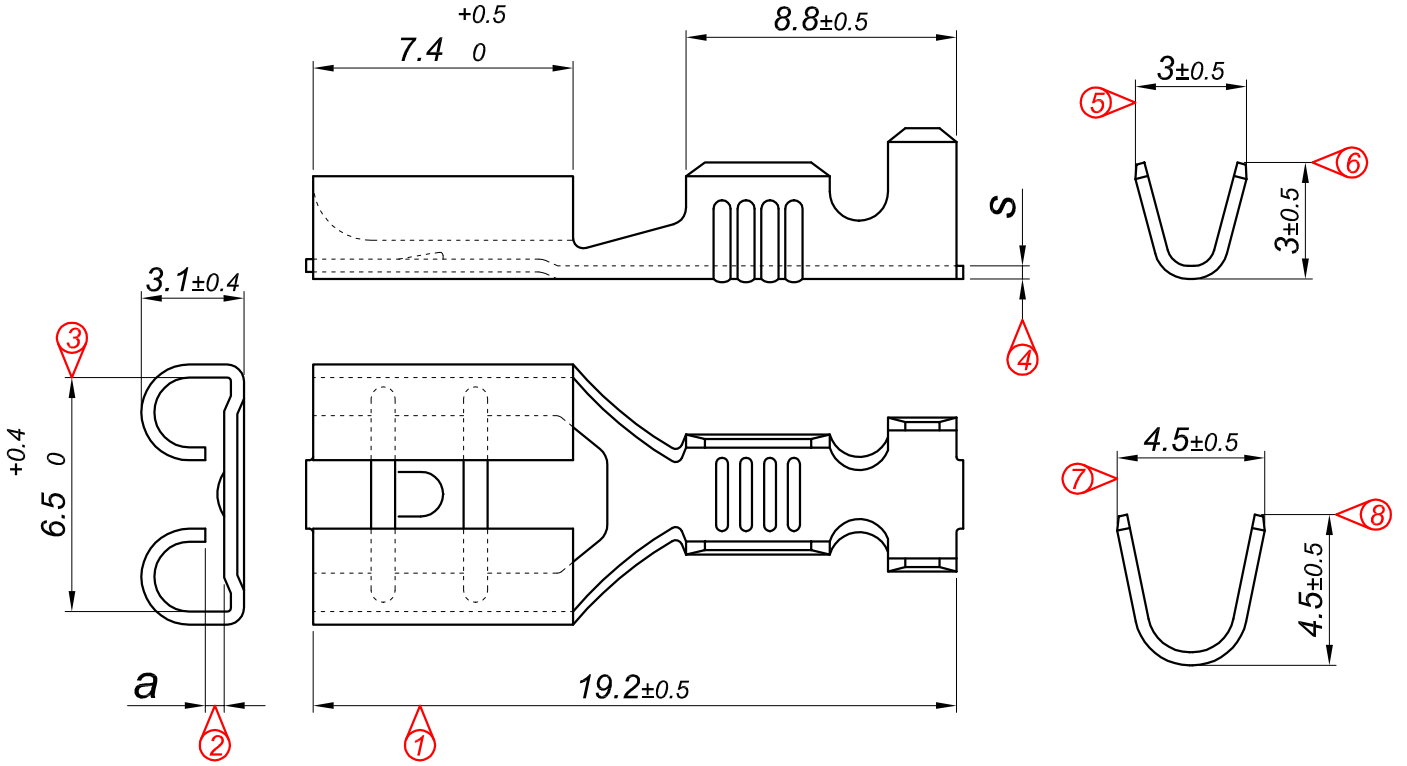

Perspektif
Perspective

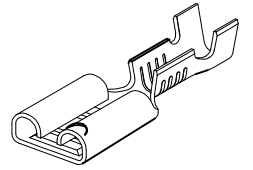

Kalıp çıkış yönü
Mold output direction

Makara açılım yönü
Reel opening direction

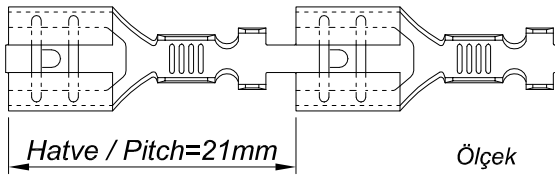

Kablo Kesiti
Wire Section : 0.50 - 1 mm²

Resim üzerinden ölçü almayınız
do not measure on drawing

Tarih / Date	09.06.2011	İmza / Signature	Ölçek / Scale			
Çizen / Desing	M.Yağcı		5 / 1	No		
Onay / Approval	S.Gölcük				Değişiklik / Revision	Tarih/Date
	Parça Adı: Part Name	STANDART DIŞI FİŞ KÜÇÜK AYAK 6.3			Parça Kodu: Part Code	TD 2113